

MS-Q QUADRUS™ HAND HELD IMAGER

The MS-Q Quadrus™ imagers are optimized to read bar codes and 2D symbols that use direct part mark (DPM) methods. It is the most aggressive hand held imager available for decoding symbols on low contrast substrates such as metal, plastic, rubber, and glass with marking methods such as dot peen and laser/chemical etch.

Containing custom optics and Microscan's Quadrus decode algorithms, the MS-Q combines the decoding power of Microscan's popular smart camera Quadrus EZ™ into a portable hand held device.

QUADRUS™ IMAGER FOR DIRECT MARK READING

Optical Options:

The MS-Q Quadrus™ hand held imager is available in two optical options:

- The high resolution version is custom designed to optimize resolution for reading small 2D symbols in direct part mark applications.
- The standard resolution version is suitable for reading all printed bar code methods plus many applications with directly marked symbols.



Applications:

Automotive and aerospace industries are actively tracing all parts with bar codes or 2D symbols. The most common practices are to permanently imprint a Data Matrix or bar code symbol directly into the metal component surfaces.

Electronics manufacturers now track virtually all printed circuit boards and most components by small bar codes or Data Matrix symbols, typically marked by laser or etched methods.

The MS-Q Quadrus™ imager is ideal for any application to track parts with marked with bar codes or 2D symbols.

Ease of Use:

All MS-Q imagers feature point-and-click targeting with a red laser spot to quickly center the symbol in the field of view. Beeper, vibrator, and multi-purpose LEDs provide real-time feedback to signal successful decoding.

System Integration:

All MS-Q imagers are available in 3 configuration options that provide effortless connectivity:

- **Batch:** A wireless way to collect thousands of decoded symbols for later download, capable of performing more than 4000 reads from a single battery charge and buffer a minimum of 1 MB of data in non-volatile memory.*
- **Cabled:** Cabled units can be connected in two ways: USB and RS-232.
- **Bluetooth:** Wireless data transmission using Bluetooth™ class 1 radio with a 328' (100 m) operating range.

*For batch and Bluetooth options a 1300 mA Lithium-Ion battery is included.

Symbologies:

The MS-Q Quadrus™ imagers read the following codes:

2D Symbologies:

- MaxiCode
- Aztec Code
- QR Code
- Data Matrix (ECC 0-200)

Stacked Symbologies:

- UCC Composite
- Micro PDF417
- PDF417 (Macro support)

Linear Bar Codes:

- Codabar
- GoCode
- RSS
- Code 128
- Int 2 of 5
- Codablock F
- Code 93
- Code 39
- UPC/EAN/JAN
- Postal Codes

MS-Q Accessories:

- Long-life 1300 mA lithium-Ion battery
- Bluetooth modem (serial gateway) with 328' (100 m) operating range
- Two-bay battery charger
- RS-232 kit

MICROSCAN®

MS-Q QUADRUS™ IMAGER FOR DIRECT PART MARK READING

Specifications and Options

IMAGER MECHANICAL

Height: 1.3" (33 mm)
Width: 1.8" (46 mm)
Depth: 4.3" (109 mm)
Weight: 2.5 oz. (71.5 g),
 not including cable

HANDLE MECHANICAL

Height: 3.8" (96.5 mm)
Width: 1.2" (30mm)
Depth: 1.4" (36 mm)
Weight: 1.2 oz. (59.8 g)

ADDITIONAL PHYSICAL CHARACTERISTICS

Battery Weight: 2.1 oz. (59.5 g)
Battery Blank: .5 oz. (13.6 g)
Cable Length: 6' (1.8 m)

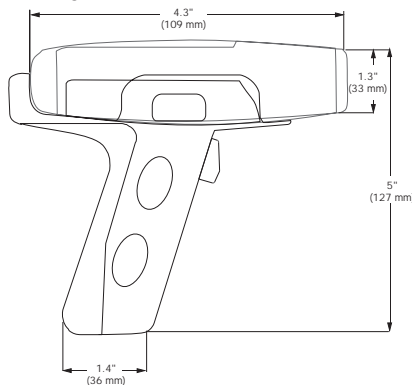

ENVIRONMENTAL

Operating Temperature: 0° to 40°C (32° to 104°F)
Storage Temperature: -20° to 60° C (-4 to 140°F)
Humidity: 5 to 90% (non-condensing)

CE STANDARDS

Immunity: EN 55024
ESD: EN 61000-4-2 **Radiated RF:** EN61000-4-3
Keyed Carrier: ENV50204 **EFT:** EN61000-4-4
Conducted RF: EN61000-4-6,
Emissions: EN55022, Class B Radiated,
 Class B Conducted

LIGHT COLLECTION OPTIONS

Sensor: CMOS, progressive scan, 1.33 MP (1024 by 1280), 256 gray scale
Standard Resolution Field of View:
 Near: 21.5° horizontal by 16.2° vertical
 Far: 22.9° horizontal by 11.6° vertical
High Resolution Field of View:
 Near & Far: 21° horizontal by 13° vertical
Standard Resolution Focal Point:
 Near: 4" (101.6 mm)
 Far: 9" (228.6 mm)
High Resolution Focal Point:
 Near: 2.75" (70 mm)
 Far: 4.5" (115 mm)
Sensor Array:
 Near Field: 1024 by 640 (default)
 Far Field: 1024 by 640 (default)

SYMBOLGY TYPES

Linear Bar Codes: Code 39, Code 128, I2 of 5, RSS, UPC/EAN, Codabar, Codablock F, Go Code, Code 93, PLANET, PostNet, KIX Code, Postal Codes
Stacked Symbolgies: PDF417, UCC Composite, Micro PDF417
2D Symbolgies: Data Matrix (ECC 0-200), MaxiCode, Aztec Code, QR Code

READ PARAMETERS

Pitch: ±60° (front to back) **Skew:** ±60° **Tilt:** 360°
Focal Range: 1 to 20" (25 to 508 mm)
Rotational Tolerance: ±180°
Print Contrast Resolution: 25 percent (bar codes); 35 percent (PDF417); absolute dark/light reflectance differential, measure at 650 nm.
Target Beam: Visible Laser Diode at 630 nm. Class 2

NEAR/FAR FIELD FOCAL DISTANCE COMPARISON CHART

MEASUREMENT

Shown in inches (mm)

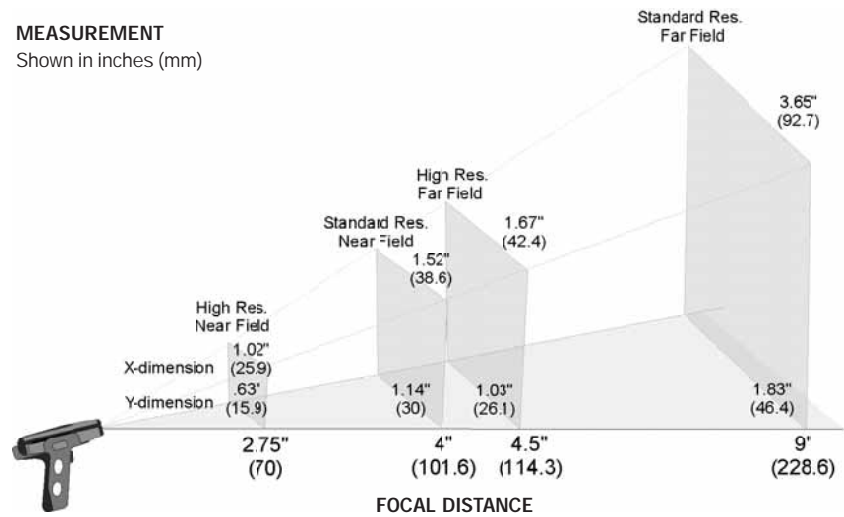

READ RANGES

Narrow Bar-Width	Read Range Distance
.005" (.127 mm)	1.75 to 2.5" (44.4 to 63.5 mm)
.0075" (.191 mm)	1.75 to 4" (44.4 to 101.6 mm)
.010" (.254 mm)	1.75 to 4.75" (44.4 to 102.6 mm)
.015" (.381 mm)	1.75 to 6" (44.4 to 152.3 mm)
.020" (.508 mm)	1.75 to 6.5" (44.4 to 165.1 mm)

Ranges based on Grade A, Data Matrix symbols.

Ambient Light Immunity: Sunlight: Up to 9,000 ft-candles 96,890 lux

Shock: Withstands multiple drops of 6.5' (2 meters) to concrete

INDICATORS

LED Indicators: Memory status, Battery power, Successful decode, and Connection status
Programmable Indicators: Beeper or Vibrate option; communicates scanner operation and communication functions to user

IMAGE OUTPUT OPTIONS

Format: Jpeg, Raw (uncompressed)
Time Stamp: Interval logging

COMMUNICATION PROTOCOLS

Standard Interface: USB
Optional Interface: RS-232, Bluetooth Class 1 Radio at 328' (100 m)

ELECTRICAL

Power Requirements: 5 VDC (mA)
Typical: 310 **Peak:** 310 **Sleep:** 3

Bluetooth Radio at 295' (90 m) away (mA):
Typical: 280 **Peak:** 350 **Idle:** 96 **Sleep:** 3

Bluetooth Radio at 33' (10 m) away (mA):
Typical: 260 **Peak:** 350 **Idle:** 96 **Sleep:** 3

Battery Life: Battery with radio will support 4000 read/transmits per charge including 8 hours of standby interval.

SAFETY CERTIFICATIONS

Designed for: FCC, CE

ISO CERTIFICATION

Issued by RWTÜV, USA Inc.
 ISO 9001:2000 – Cert No. 03-1212

FIELD OF VIEW, STANDARD RESOLUTION

Near Field of View	
Distance (inches/mm)	Field of View Size (1024 x 640 pixel, Default)
4" (101.6)	1.52 X 1.14" (38.6 x 30 mm)
Far Field of View	
9" (228.6)	3.65 X 1.83" (92.7 x 46.4 mm)

FIELD OF VIEW, HIGH RESOLUTION

Near Field of View	
Distance inches/mm	Field of View Size (1024 x 640 pixel, Default)
2" (50.8)	.74 X .46" (18.8 x 11.6 mm)
2.5" (63.5)	.93 X .57" (23.5 x 14.5 mm)
2.75" (69.9)	1.02 X .63" (25.9 x 15.9 mm)
3" (76.2)	1.11 X .68" (28.3 x 17.4 mm)
3.5" (88.9)	1.3 X .80" (33 x 20.3 mm)
4" (101.6)	1.48 X .91" (37.7 x 23.2 mm)
Far Field of View	
2" (50.8)	.74 X .46" (18.8 x 11.6 mm)
2.5" (63.5)	.93 X .57" (23.5 x 14.5 mm)
3" (76.2)	1.11 X .68" (28.2 x 17.4 mm)
3.5" (88.9)	1.3 X .80" (32.9 x 20.3 mm)
4" (101.6)	1.48 X .91" (37.6 x 23.2 mm)
4.5" (114.3)	1.67 X 1.03" (42.4 x 26.1 mm)
5" (127)	1.85 X 1.14" (47.1 x 28.9 mm)
5.5" (139.7)	2.04 X 1.25" (51.8 x 31.8 mm)
6" (152.7)	2.22 X 1.37" (56.5 x 34.7 mm)
6.5" (165.1)	2.41 X 1.48" (61.2 x 37.6 mm)

MICROSCAN®

Microscan Systems, Inc.

Tel 425 226 5700/ 800 251 7711

Fax 425 226 8250

Microscan Europe

Tel 31 172 423360/ Fax 31 172 423366

Microscan Asia Pacific R.O.

Tel 65 6846 1214 / Fax 65 6846 4641

www.microscan.com

www.quadrus-ez.com

Tech Support: helpdesk@microscan.com

Product Information: info@microscan.com

©2004 Microscan Systems, Inc.

Specifications subject to change, 08/04 - Base B